

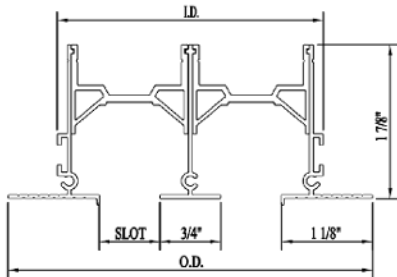

- Mud-in, recessed flange frame to be taped & plastered over.
- Fully extruded, high quality aluminum construction.
- Available in any length. Lengths over 84" are joined together with provided alignment pins for continuous appearance.
- Available on 1/2" increments as standard. Custom sizes available down to 1/16" increments.
- Available with durable powder coat finish.

### Width Dimensions by Slot



I.D. = Inside Dimension      O.D. = Outside Dimension

# OF SLOTS	1/2" SLOT		3/4" SLOT		1" SLOT	
	I.D.	O.D.	I.D.	O.D.	I.D.	O.D.
1	1-5/8"	2-3/4"	1-7/8"	3"	2-1/8"	3-1/4"
2	2-7/8"	4"	3-3/8"	4-1/2"	3-7/8"	5"
3	4-1/8"	5-1/4"	4-7/8"	6"	5-5/8"	6-3/4"
4	5-3/8"	6-1/2"	6-3/8"	7-1/2"	7-3/8"	8-1/2"

### 1. Select a Slot Width

- 50 - 1/2" slot
- 75 - 3/4" slot
- 10 - 1" slot

### 2. Select a Number of Slots

- 1 - 1 Slot
- 2 - 2 Slots
- 3 - 3 Slots
- 4 - 4 Slots

### 3. Select a Mounting Option

- A - Screw Holes
- C - Concealed Bracket
- TB - No Mounting
- D - Concealed Screw Holes

### 4. Select an End Configuration

- E2 - Both Ends
- E1 - One End
- E0 - None

### 5. Specify the Length Dimension

- Inches     MM    \_\_\_\_\_

### 6. Select a Finish

- W - White



### 7. Select a Lead Time

- 3 Day Ship
- Next Friday
- Standard Delivery

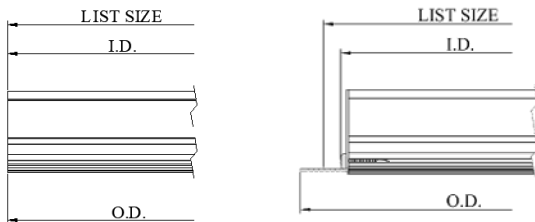
### Length Dimensions for End Configurations



I.D. = Inside Dimension      O.D. = Outside Dimension

			
	<b>E2</b> - Both Ends	<b>E1</b> - One End	<b>E0</b> - Open Ends
I.D.	List - 1/2"	List - 1/4"	List Size
O.D.	List + 1-1/2"	List + 3/4"	List Size

Invisible lip design allows for a true frameless appearance, and easier installation.

**3 DAY SHIP**  
ANY SIZE. ANY MODEL.  
**GUARANTEED**

### Mitred Corner

See Slot Linear options page for more details.

- MC 90 - 90° 
- MC 135 - 135° 

Project / Location: \_\_\_\_\_

Architect: \_\_\_\_\_

Engineer: \_\_\_\_\_

Contractor: \_\_\_\_\_

## MOUNTING

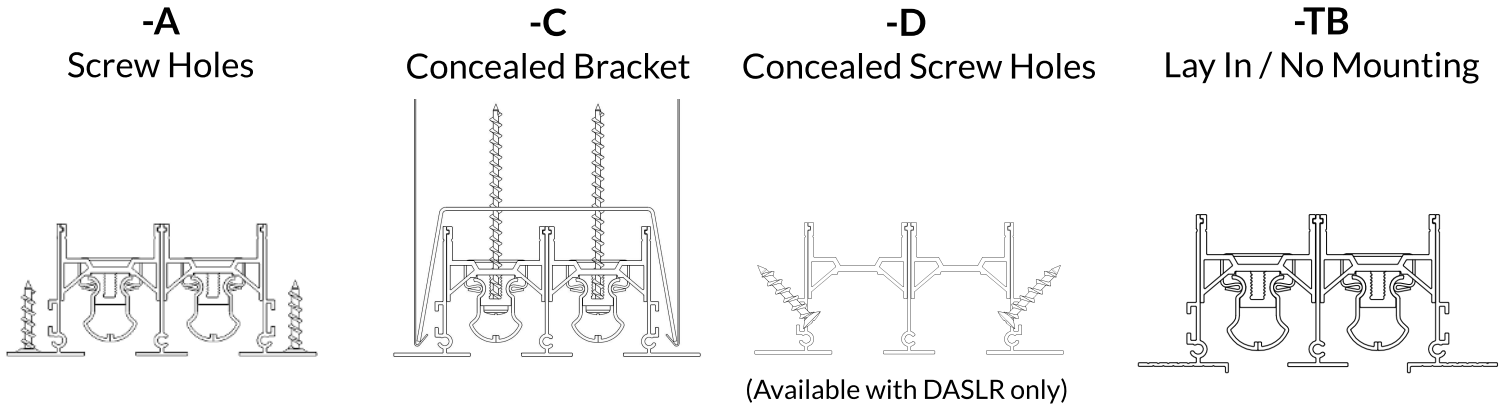

## AIR FLOW PATTERNS

\* For diffusers with more than 2 slots, use in combination to achieve desired air pattern

### DASL - 1 Slot

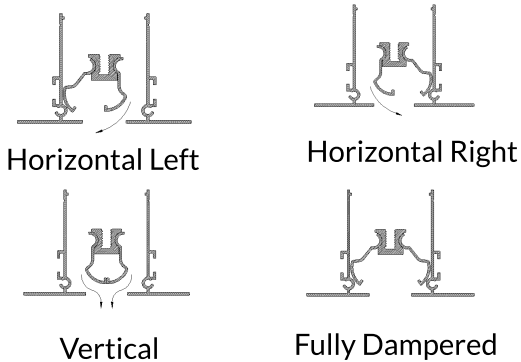

### DASL - 2 Slot

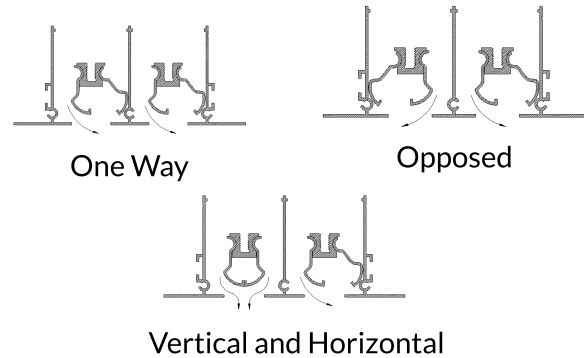

## MITRED CORNERS

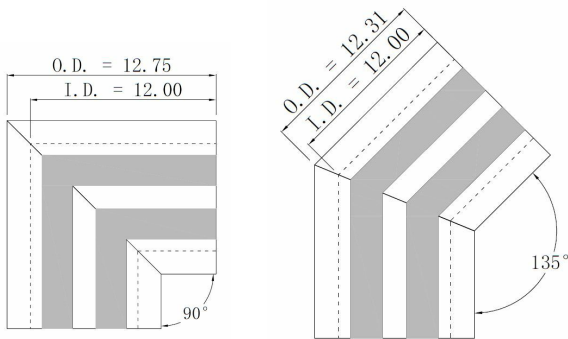

Mitred corners available at 90° (MC 90) and 135° (MC 135) as standard.

Corner units are provided with alignment pins for a precision match to straight sections.

O.D. and I.D., as shown in the diagram, are the same for 1-4 slots and all slot widths.

## FIELD CUTTING

DASL are ordered to length from factory but can be cut to size in the field. Use a fine-tooth, high-speed, carbon blade for cutting aluminum.

A maximum of 3" can be cut from each end (X).

For adjustments of more than 2" slide the retaining clip against support.

Diffusers can be adjusted up to 6" by cutting both ends.

If end caps are included remove before cutting and reattach once cut.

