

- Heavy-duty, extruded aluminum flange frame.
- Fixed, non-drainable blades on 2" spacing.
- J-blade design minimizes water ingress while maximizing free area.
- Nominal 43% free area, based on 48" x 48" louver.
- Mullions used for sizes over 36" in length.
- Bird screen included standard. Insect screen can be specified.
- Available with AAMA 2605 powder coat paint for high-performance exterior finishes.

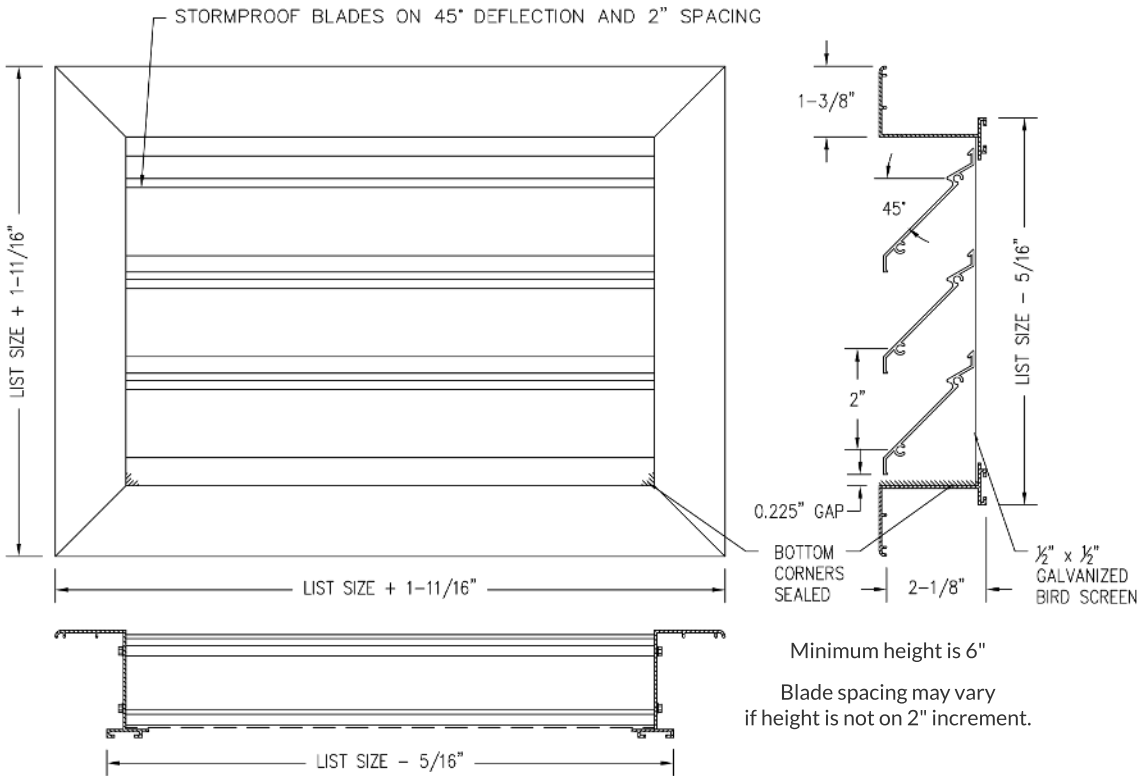

Material	6063-T5
Wall Thickness	0.080"
Blade Thickness	0.080"
Blade Angle	45°
Blade Spacing	2"
Mullion Start	36"
Minimum Size	3 x 6"
Maximum Size (Single Piece)	120 x 72" 72 x 120"
Free Area (Based on 48"x 48")	43%

**3 DAY SHIP**  
ANY SIZE. ANY MODEL. GUARANTEED

**1. Specify Quantity**

\_\_\_\_\_

**2. Specify the Length x Height Dimensions**

Available on 1" increments as standard. Custom sizes down to 1/16" increments.

\_\_\_\_\_ x \_\_\_\_\_  inches  mm

**3. Select a Finish**

- W - White
- S - Silver
- B - Brown
- M - Mill
- FB - Flat Black

- Select \_\_\_\_\_
- Special Order \_\_\_\_\_
- AAMA 2605 Powder Coat \_\_\_\_\_

**4. Select a Lead Time**

- 3 Day Ship
- Next Friday
- Standard Delivery

**Additional Options**

- IS - Insect Screen
- A - Screw Holes

Project / Location: \_\_\_\_\_

Architect: \_\_\_\_\_

Engineer: \_\_\_\_\_

Contractor: \_\_\_\_\_



Scan for more product information.

Free Area – ft<sup>2</sup> (m<sup>2</sup>)

OPENING LENGTH in inches (mm)

		12	18	24	30	36	42	48	54	60	66	72	78	84	90	96	102	108	114	120					
		300	450	600	750	900	1050	1200	1350	1500	1700	1850	2000	2150	2300	2450	2600	2750	2900	3050					
<b>8</b>		0.16	0.26	0.36	0.45	0.55	0.61	0.71	0.81	0.90	1.00	1.10	1.16	1.26	1.36	1.45	1.55	1.65	1.71	1.81					
	200	0.02	0.02	0.03	0.04	0.05	0.06	0.07	0.08	0.08	0.09	0.10	0.11	0.12	0.13	0.14	0.14	0.15	0.16	0.17					
<b>12</b>		0.30	0.48	0.66	0.84	1.02	1.15	1.33	1.51	1.69	1.87	2.05	2.17	2.35	2.53	2.71	2.89	3.07	3.20	3.38					
	300	0.03	0.04	0.06	0.08	0.10	0.11	0.12	0.14	0.16	0.17	0.19	0.20	0.22	0.24	0.25	0.27	0.29	0.30	0.31					
<b>18</b>		0.51	0.82	1.12	1.43	1.74	1.94	2.25	2.56	2.86	3.17	3.48	3.68	3.99	4.29	4.60	4.91	5.21	5.42	5.73					
	450	0.05	0.08	0.10	0.13	0.16	0.18	0.21	0.24	0.27	0.29	0.32	0.34	0.37	0.40	0.43	0.46	0.48	0.50	0.53					
<b>24</b>		0.72	1.15	1.59	2.02	2.45	2.74	3.17	3.60	4.04	4.47	4.90	5.19	5.62	6.06	6.49	6.92	7.35	7.64	8.08					
	600	0.07	0.11	0.15	0.19	0.23	0.25	0.29	0.33	0.38	0.42	0.46	0.48	0.52	0.56	0.60	0.64	0.68	0.71	0.75					
<b>30</b>		0.93	1.49	2.05	2.61	3.16	3.54	4.10	4.65	5.21	5.77	6.33	6.70	7.26	7.82	8.38	8.94	9.49	9.87	10.42					
	750	0.09	0.14	0.19	0.24	0.29	0.33	0.38	0.43	0.48	0.54	0.59	0.62	0.67	0.73	0.78	0.83	0.88	0.92	0.97					
<b>36</b>		1.14	1.82	2.51	3.19	3.88	4.33	5.02	5.70	6.39	7.07	7.76	8.21	8.90	9.58	10.26	10.95	11.63	12.09	12.77					
	900	0.11	0.17	0.23	0.30	0.36	0.40	0.47	0.53	0.59	0.66	0.72	0.76	0.83	0.89	0.95	1.02	1.08	1.12	1.19					
<b>42</b>		1.35	2.16	2.97	3.78	4.59	5.13	5.94	6.75	7.56	8.37	9.18	9.72	10.53	11.34	12.15	12.96	13.77	14.31	15.12					
	1050	0.13	0.20	0.28	0.35	0.43	0.48	0.55	0.63	0.70	0.78	0.85	0.90	0.98	1.05	1.13	1.20	1.28	1.33	1.41					
<b>48</b>		1.56	2.50	3.43	4.37	5.30	5.93	6.86	7.80	8.74	9.67	10.61	11.23	12.17	13.10	14.04	14.98	15.91	16.54	17.47					
	1200	0.14	0.23	0.32	0.41	0.49	0.55	0.64	0.72	0.81	0.90	0.99	1.04	1.13	1.22	1.30	1.39	1.48	1.54	1.62					
<b>54</b>		1.77	2.83	3.89	4.96	6.02	6.73	7.79	8.85	9.91	10.97	12.04	12.74	13.80	14.87	15.93	16.99	18.05	18.76	19.82					
	1350	0.16	0.26	0.36	0.46	0.56	0.62	0.72	0.82	0.92	1.02	1.12	1.18	1.28	1.38	1.48	1.58	1.68	1.74	1.84					
<b>60</b>		1.98	3.17	4.36	5.54	6.73	7.52	8.71	9.90	11.09	12.27	13.46	14.25	15.44	16.63	17.82	19.00	20.19	20.98	22.17					
	1500	0.18	0.29	0.40	0.51	0.63	0.70	0.81	0.92	1.03	1.14	1.25	1.32	1.43	1.54	1.66	1.77	1.88	1.95	2.06					
<b>66</b>		2.19	3.50	4.82	6.13	7.44	8.32	9.63	10.95	12.26	13.57	14.89	15.76	17.08	18.39	19.70	21.02	22.33	23.21	24.52					
	1700	0.20	0.33	0.45	0.57	0.69	0.77	0.89	1.02	1.14	1.26	1.38	1.46	1.59	1.71	1.83	1.95	2.07	2.16	2.28					
<b>72</b>		2.40	3.84	5.28	6.72	8.16	9.12	10.56	12.00	13.44	14.88	16.31	17.27	18.71	20.15	21.59	23.03	24.47	25.43	26.87					
	1850	0.22	0.36	0.49	0.62	0.76	0.85	0.98	1.11	1.25	1.38	1.52	1.60	1.74	1.87	2.01	2.14	2.27	2.36	2.50					
<b>78</b>		2.61	4.17	5.74	7.31	8.87	9.91	11.48	13.04	14.61	16.18	17.74													
	2000	0.24	0.39	0.53	0.68	0.82	0.92	1.07	1.21	1.36	1.50	1.65													
<b>84</b>		2.82	4.51	6.20	7.89	9.58	10.71	12.40	14.09	15.79	17.48	19.17													
	2150	0.26	0.42	0.58	0.73	0.89	1.00	1.15	1.31	1.47	1.62	1.78													
<b>90</b>		3.03	4.85	6.66	8.48	10.30	11.51	13.33	15.14	16.96	18.78	20.59													
	2300	0.28	0.45	0.62	0.79	0.96	1.07	1.24	1.41	1.58	1.74	1.91													
<b>96</b>		3.24	5.18	7.12	9.07	11.01	12.31	14.25	16.19	18.13	20.08	22.02													
	2450	0.30	0.48	0.66	0.84	1.02	1.14	1.32	1.50	1.68	1.87	2.05													
<b>102</b>		3.45	5.52	7.59	9.65	11.72	13.10	15.17	17.24	19.31	21.38	23.45													
	2600	0.32	0.51	0.70	0.90	1.09	1.22	1.41	1.60	1.79	1.99	2.18													
<b>108</b>		3.66	5.85	8.05	10.24	12.44	13.90	16.09	18.29	20.48	22.68	24.87													
	2750	0.34	0.54	0.75	0.95	1.16	1.29	1.50	1.70	1.90	2.11	2.31													
<b>114</b>		3.87	6.19	8.51	10.83	13.15	14.70	17.02	19.34	21.66	23.98	26.30													
	2900	0.36	0.57	0.79	1.01	1.22	1.37	1.58	1.80	2.01	2.23	2.44													
<b>120</b>		4.08	6.52	8.97	11.42	13.86	15.49	17.94	20.39	22.83	25.28	27.73													
	3050	0.38	0.61	0.83	1.06	1.29	1.44	1.67	1.89	2.12	2.35	2.58													

OPENING HEIGHT in inches (mm)



Scan for more product information.

## PRESSURE DROP

Louver Test Size: 48" x 48" (120mm x 120mm)

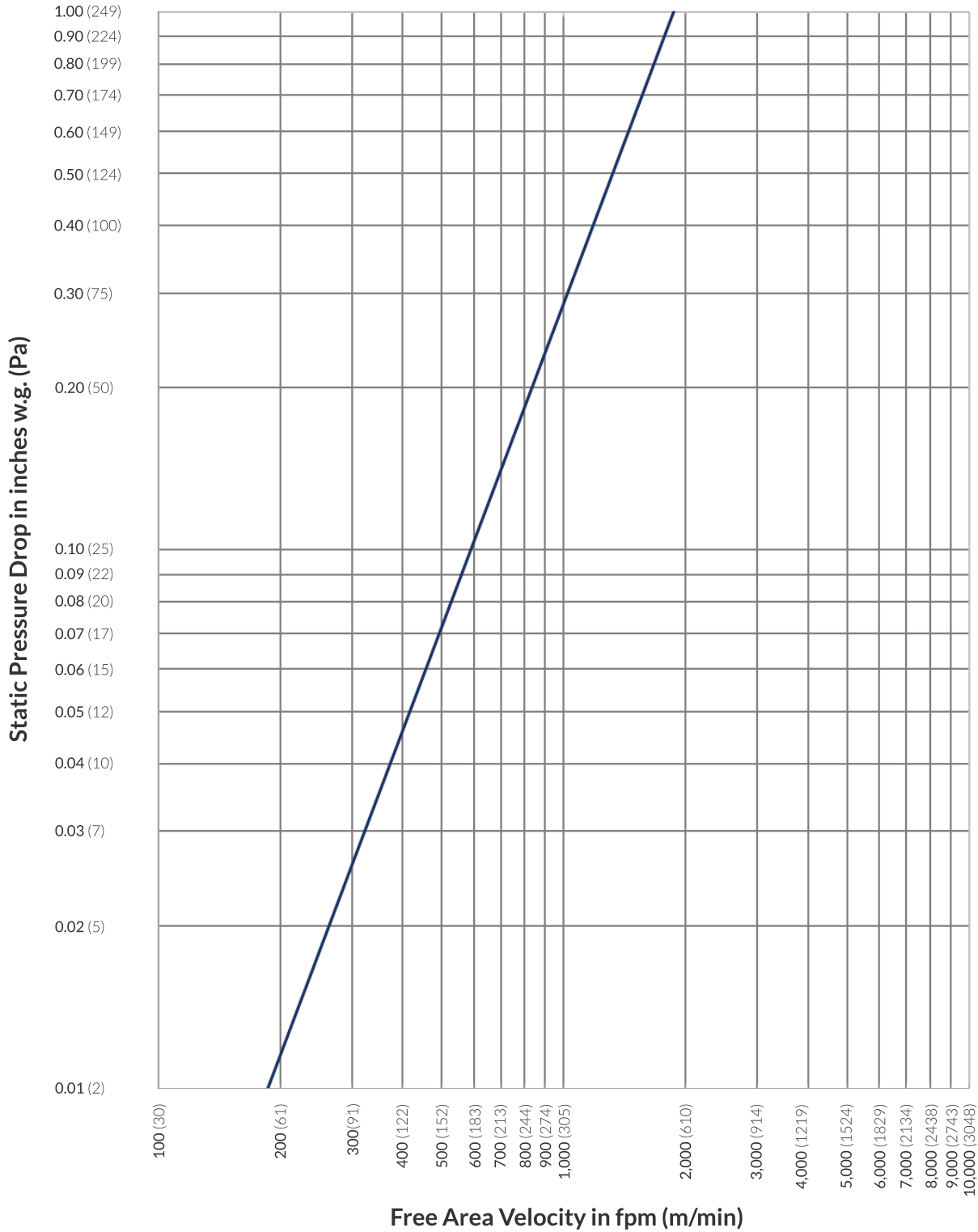

Scan for more product information.