

DARHEJ-45 | Mud-In Extruded Return Grille w/ Mud-In Flange

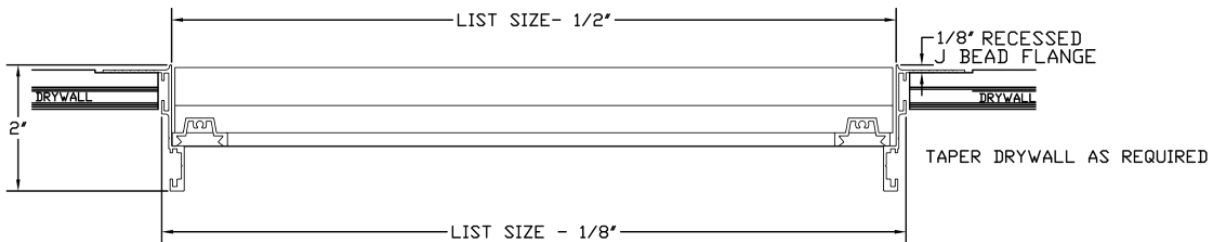

- Mud-in, recessed flange frame to be taped & plastered over.
- Horizontal blades fixed on 45° deflection with 3/4" spacing.
- Constructed with high-quality, fully-extruded aluminum with blades designed for high efficiency.
- All supports are hidden behind blades for a continuous appearance.
- Countersunk #6 screw hole mounting c/w painted screws.
- Available on 2" increments as standard. Custom sizes available down to 1/16" increments.
- Available with durable powder coat finish.

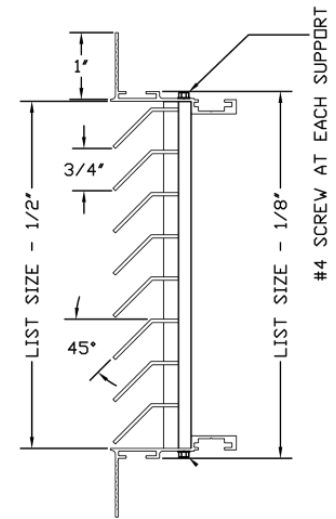
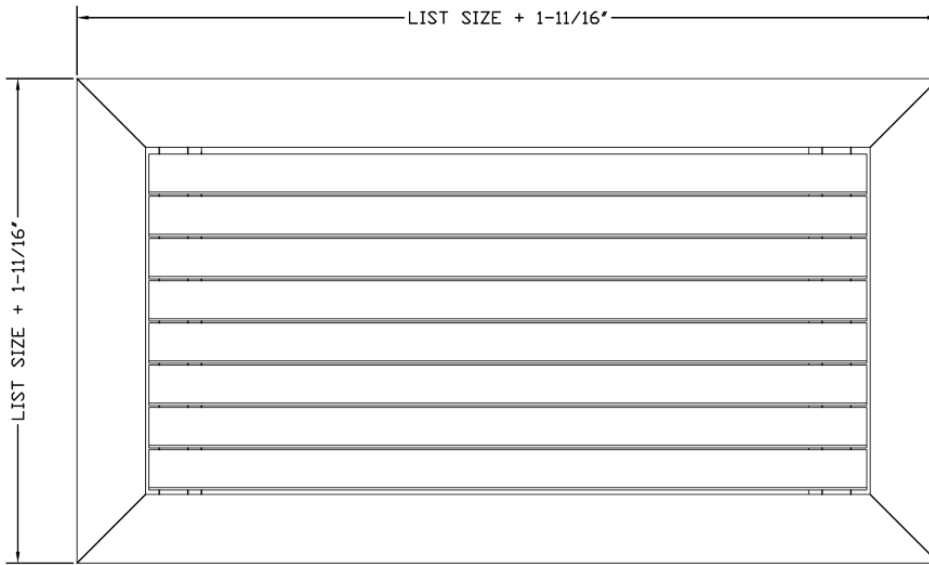

3 DAY SHIP
ANY SIZE. ANY MODEL.
GUARANTEED

1. Specify the Length x Height Dimensions

Inches MM _____ x _____

2. Select a Finish

- W - White FB - Flat Black
 S - Silver Special: _____
 B - Brown
 M - Mill

3. Select a Lead Time

- 3 Day Ship
 Next Friday
 Standard Delivery

Additional Options

- D - Opposed Blade Damper
 TB - No Screw Holes

Project / Location: _____
Architect: _____
Engineer: _____
Contractor: _____

