

Bar Linear Floor Grille

DAF



- Reinforced for floor use
- Aluminum extruded frame with mechanically locked corners
- Fully extruded construction for a stylish appearance
- Fixed blades designed for long straight air throw
- Split air pattern with 0°, 15° and 30° degree blades designed for an even airflow distribution
- Durable powder coat painted finish
- Available in White, Silver, Brown, Mill or Special*

Available only in sizes shown

Size	Size	Size	Size
L x H	L x H	L x H	L x H
3" x 8"	4" x 8"	5" x 8"	6" x 8"
3" x 10"	4" x 10"	5" x 10"	6" x 10"
3" x 12"	4" x 12"	5" x 12"	6" x 12"
3" x 14"	4" x 14"	5" x 14"	6" x 14"
3" x 16"	4" x 16"	5" x 16"	6" x 16"
3" x 18"	4" x 18"	5" x 18"	6" x 18"

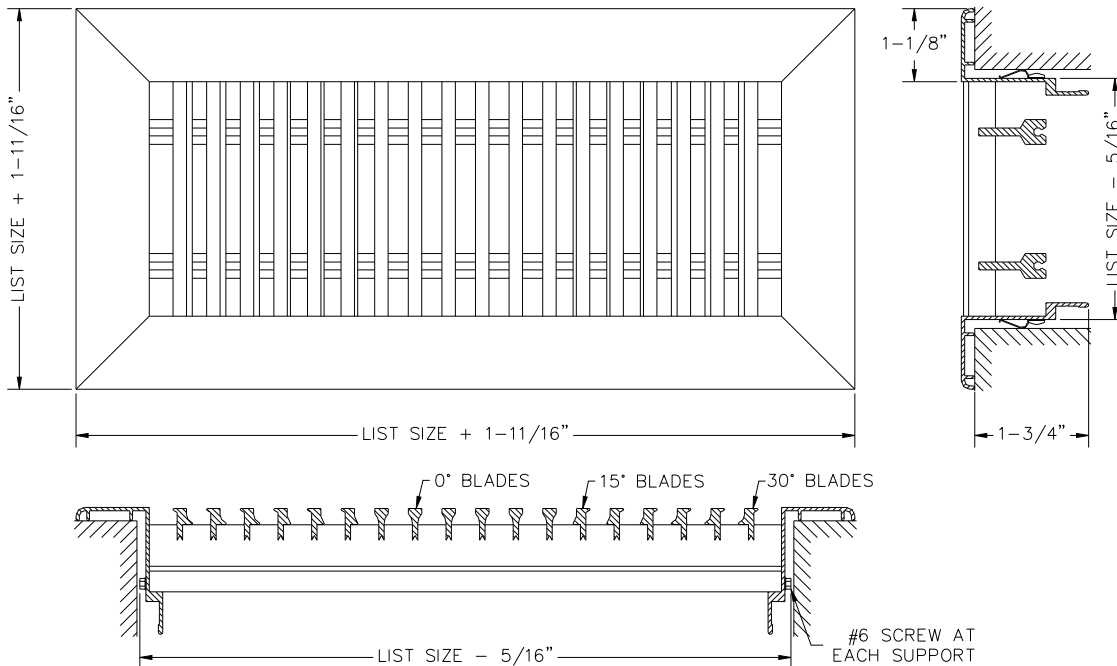

MODEL	DAF
FACE BLADES	Fixed
REAR BLADES	n/a
DAMPER	n/a
MATERIAL	Aluminum
COLOR	White/Silver/Mill Brown/Special*

JOB NAME: _____

LOCATION: _____

ARCHITECT: _____

ENGINEER: _____

CONTRACTOR: _____